



INSTALLATION INSTRUCTIONS

Part #	Description
WFO 9500	2021+ Ford Bronco – 4-Door Rear Cargo Basket - Aluminum

10076 Streeter Road Suite #7, Auburn, CA 95602
 Phone: 530.268.9494 www.wfoconcepts.com

WFO 9500

BILL OF MATERIALS		
WFO 1400	40" x 25" Aluminum Basket	Qty. 1
C-37003-01	Driverside Cage Plate	Qty. 1
C-37003-02	Passengerside Cage Plate	Qty. 1
45-0825	M8x1.25mmx25mm Hex Bolt	Qty. 4
45-0830	M8x1.25mmx30mm Hex Bolt	Qty. 2
454508	M8 Lock Washer	Qty. 6
453508	M8 Flat Washer	Qty. 6
9540K48	Rubber Bumper	Qty. 2
336172	10-24 x 3/4" SS Button Allen Bolt	Qty. 2
332610	10-24 SS Nylock Nut	Qty. 2
5993K72	1/2"-13 Knob	Qty. 4
92825A419	3/4" x 3/8" Plastic Spacer	Qty. 2

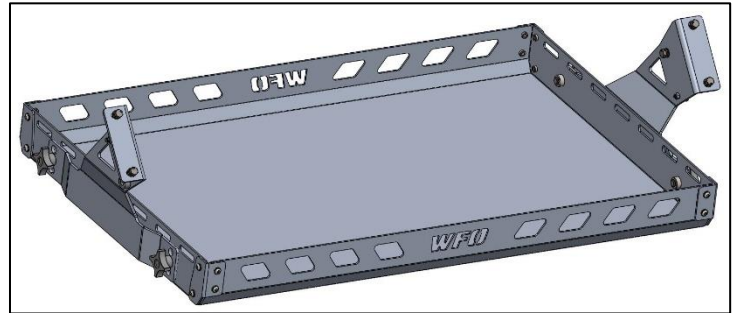

TOOLS NEEDED
5/32", 3/32" Allen Socket
13mm Socket
3/8" Drive Ratchet
3/8" Wrench
Anti-Seize

WARNING!
*** Read all instructions thoroughly from start to finish before beginning the job! If these instructions are not properly followed, severe frame, suspension, tire, or body damage may result to the vehicle!
*** WFO Concepts recommends that you exercise extreme caution when working under vehicles supported by jack stands.
*** WFO Concepts recommends all installation to be performed by a professional shop/service technician. Product failure due to improper installation will not be covered under WFO's warranty policy.

TECH NOTES:
- Whenever installing Stainless Steel Hardware it's a good idea to use Anti Seize to preventing galling of the threads.
- The corner 1/4"-20 Penn Nuts have a max torque rating of 78 in. lbs. (6.5 ft. lbs.)
- The side 1/2"-13 Penn Nuts have a max torque Rating of 692 in. lbs. (57 ft. lbs.)

REVISIONS			
REV.	DESCRIPTION	DATE	APPROVED
A	Part Released	11/29/2023	Keven K

ITEM NO.	PART NUMBER	DESCRIPTION	QTY.	Rev
1	C-37003-01	21+ Ford Bronco - Driverside Cargo Rack Bracket	1	A
2	C-37003-02	21+ Ford Bronco - Passengerside Cargo Rack Bracket	1	A
3	WFO 1400	40" x 25" Aluminum Basket	1	A
4	92825A419	3/4" x 3/8" Plastic Spacer	2	A
5	9540K48	7/8" x 3/8" Rubber Bumper	2	A
6	33-6172	10-24 x 3/4" SS Buffet Head Screw	2	A
7	33-2610	10-24 SS Nylock Nut	2	A
8	5993K72	1/2" - 13 x 3/4" Knob with Four Arm Grip	4	A
9	45-0825	M8 x 1.25 x 25mm - 8.8 Steel Hex Head Screw	4	A
10	45-0830	M8 x 1.25 x 30mm - 8.8 Steel Hex Head Screw	2	A
11	45-4508	M8 Lock Washer	6	A
12	45-3508	M8 Flat Washer	6	A

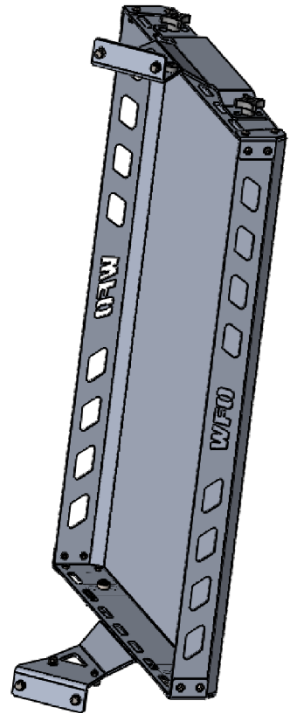
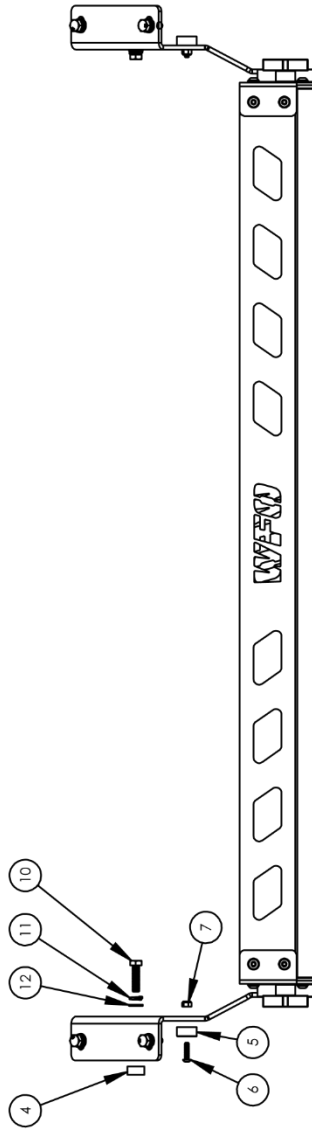
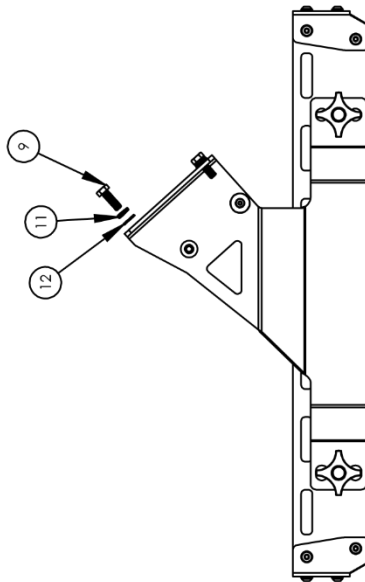
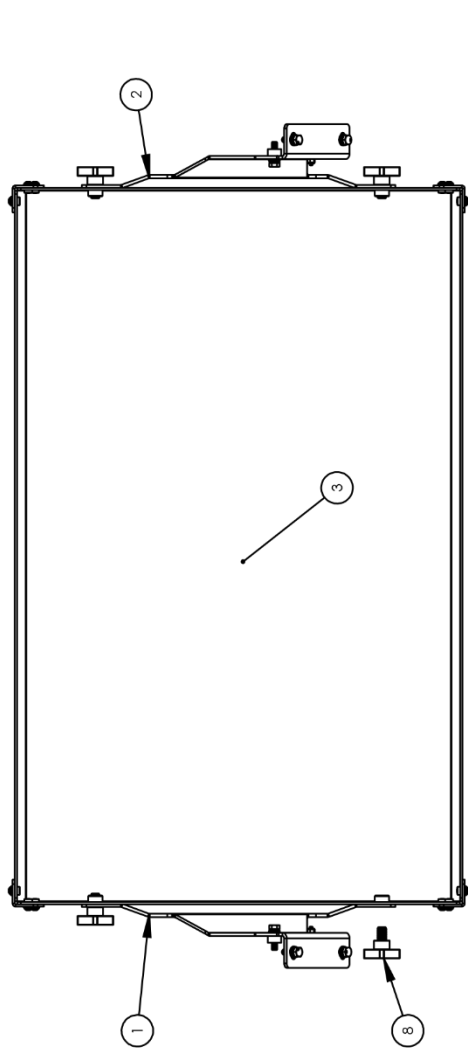

	10076 Streeleer Rd. - Suite 7 Auburn, CA 95602 Phone: 530.288.9494 WWW.WFOCONCEPTS.COM
	TITLE: 2021+ Ford Bronco - 4-Door Rear Cargo Basket
MATERIAL: ALUMINUM RAW	PART # WFO 9500
FINISH: TOLERANCES / DIMENSIONS ARE IN INCHES EXCEPT AS NOTED: ANGULAR: ±0.1° BEND: ±0.5° DEC: 2 PL ±0.01 3 PL ±0.005	REV A
DRAWN BY: KEVEN K DATE: 11/29/23 DRAWING UPDATED:	DO NOT SCALE DRAWING SHEET 1 OF 1
THE INFORMATION CONTAINED IN THIS DRAWING IS THE SOLE PROPERTY OF WFO CONCEPTS. ANY REPRODUCTION IN PART OR AS A WHOLE WITHOUT THE WRITTEN PERMISSION OF WFO IS PROHIBITED.	

ASSEMBLY:

1. If your WFO 1400 Basket is not already assembled, refer to those instructions for assembly.
2. Install the roll cage rubber isolation bumpers to the insides of each side plate. Insert the 10-24 SS Button Head Screw through the recessed side of the bumper, in to the bracket (as shown below in Fig. A), and tighten with the 10-24 Nylock Nut. And repeat on opposite side.

Fig. A

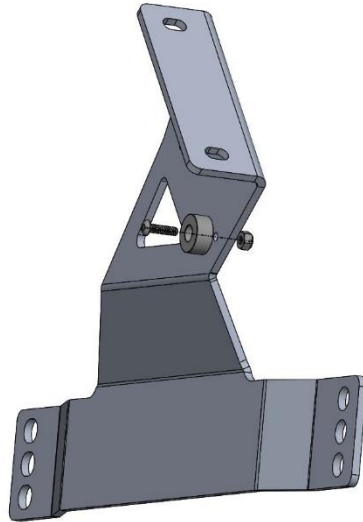

INSTALL:

1. Locate the 3 factory threaded holes in the rear part of your roll cage. Start with the longer M8-1.25 x 30mm bolt, lock washer, and washer, and insert it on the face that you previously installed the rubber bumper. Also locate the $\frac{3}{4}$ " OD plastic spacer and slip it onto the bolt after it is inserted in through the bracket, see Fig. B. Lightly start this bolt into the side of your roll cage.

Fig. B



2. Once side bolt is loosely snug, locate the shorter M8-1.25 x 25mm bolt, lock washer, and washers. You thread qty. 2 in each flange from the top side into the cage. Fig. C. DO NOT TIGHTEN any of the 3 bolts just yet. Repeat on opposite side.

Fig. C



3. Locate your WFO 1400 assembled basket and qty. (4) ½"-13 threaded knobs. Position the basket between the brackets and loosely start all 4 knobs in the chosen holes. Thread till snug. Fig. D

Fig. D

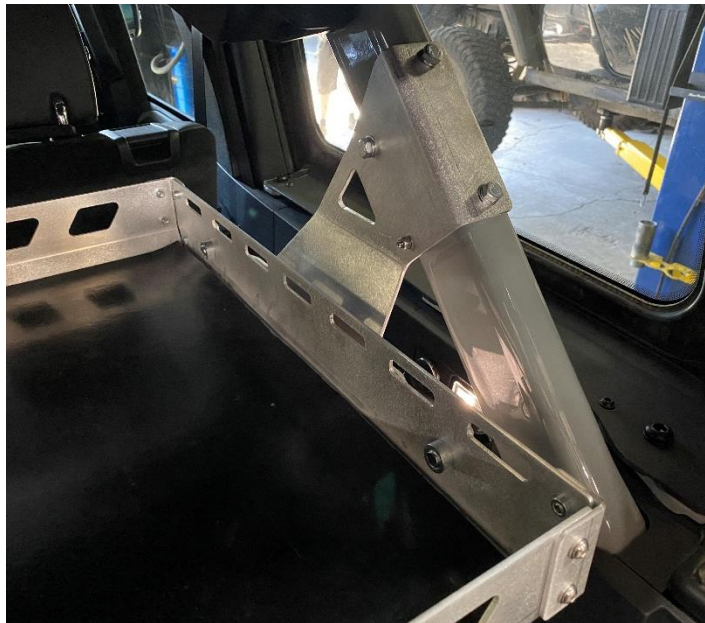

4. Once all bolts are installed and slightly snug, level the basket to the best of your abilities. Start by tightening the side M8 bolt with plastic spacer. Torque to 19 Ft.-Lbs. Lastly tighten the top 4 bolts, again you can torque them to 19 Ft. Lbs.

5. Tighten all 4 thumb screws and load up your new basket!



10076 Streater Road Suite #7, Auburn, CA 95602
Phone: 530.268.9494 www.wfoconcepts.com

Follow us on all Social Media Platforms!

Remember to share your photos and tag #WFOCONCEPTS to be featured on our page!

